

Data sheet

MS13

Digital pressure transmitter / switch
with colour change display

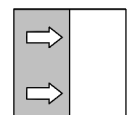

1 Product and functional description

1.1 Delivery scope

- MS13 Digital pressure transmitter / switch
- Operating instructions

The unit is supplied ex-works with standard parameters.

For accessories, please see the list in section Order code [► 10].

1.2 Performance features

Important features

- LCD colour change display
- Switchable pressure units
- 2 independent switching points with lots of configuration options
- Analogue signal output with possibility of characteristic curve spread, characteristic curve reversal and offset setting
- Characteristic curve implementation via table with max. 30 measuring points
- Complete adjustment of all parameters and measuring point protocol possible through optional transmitter PC interface.

Typical applications

- Simple pump control systems
- Monitoring of pumps and compressors
- Filling level measuring

Application areas

- Technical facility equipment (TGA)
- Process engineering
- Process technology
- Environmental technology

1.3 Intended use

The MS13 is a pressure transmitter/ switch for measuring relative pressure. The unit is suitable for measuring pressure and under-pressure in non-aggressive gas-like and fluid media.

The MS13 complies with the state-of-the-art and is safe; it also takes into account the relevant regulations and EC directives. The manufacturer will not be liable for damage arising from incorrect or improper use.

The unit was designed bearing in mind all relevant factors that could impact on its safety. Also, the unit was produced, inspected and supplied with a user manual so that if it is used in unforeseeable reasonable conditions, its safety is guaranteed for its entire service life.

1.4 Product Overview

All units of the series MS13 are supplied in an NG100 bayonet ring housing made of stainless steel.

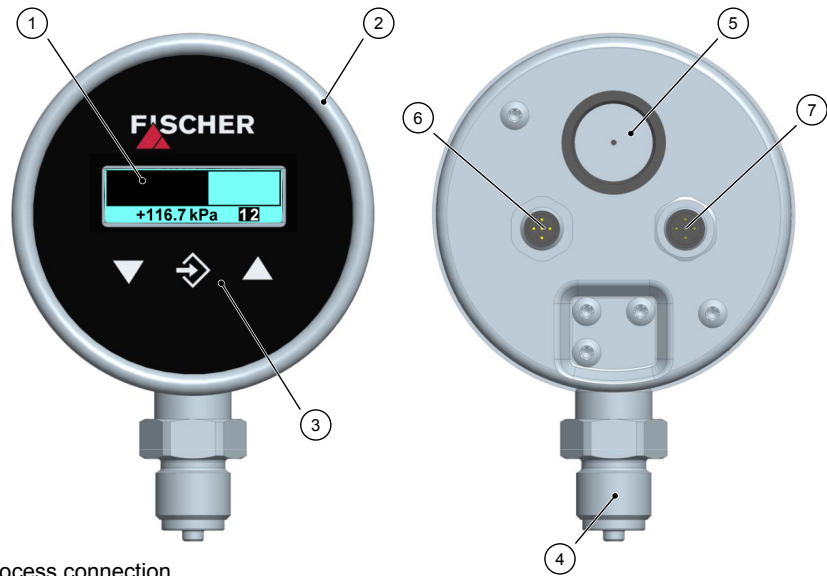

Process connection
Code **U**

Illustration 1: Product Overview

1	Colour change display	2	Bayonet ring housing
3	Keyboard	4	Process connection
5	Blowout plug	6	M12 plug 1
7	M12 plug 2		

Process connection

The following options are available for the process connection.

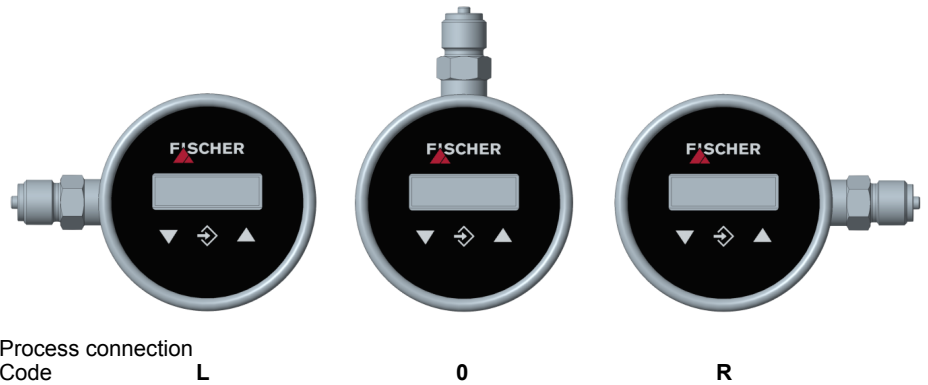

Process connection
Code **L**

0

R

Illustration 2: Process connection direction

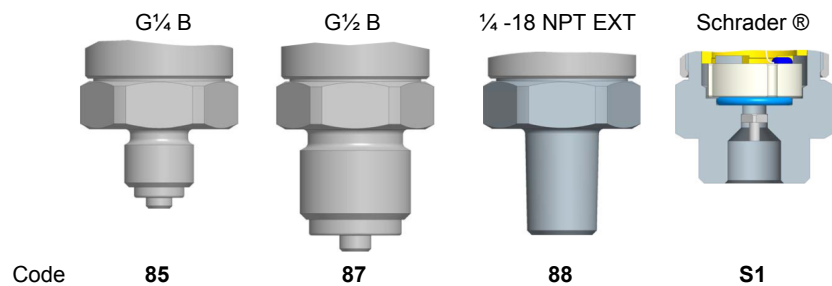

Code **85**

87

88

S1

Illustration 3: Process connections

Code	Process connection
85	Connection shanks with external thread G¼ B
87	Connection shanks with external thread G½ B
88	Connecting port with outer thread ¼ -18 NPT EXT
S1	Schrader® screw connection inner thread 7/16 UNF

Electrical connections

The power is connected using two M12 connectors.

M12 flanged connector DIN EN 61076-2-101 coding A	
Connector 1	5-pin Ms-nickel-plated
Connector 2	4-pin Ms-nickel-plated

1.5 Function diagram

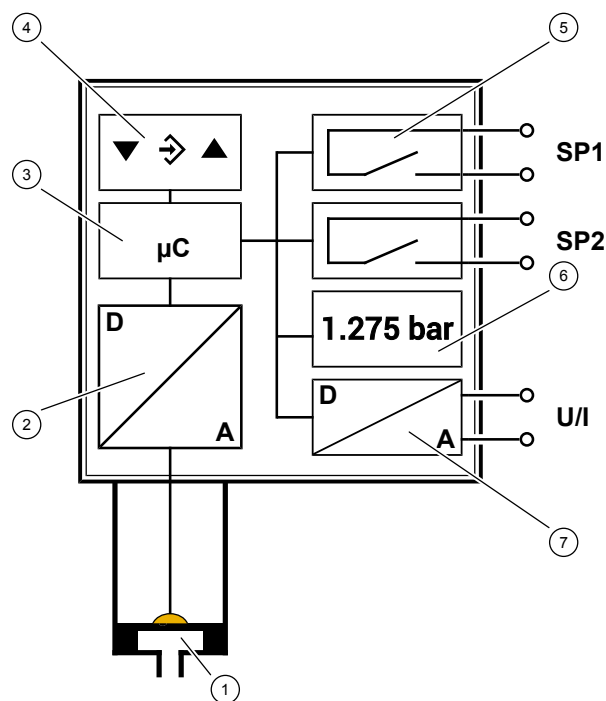

Illustration 4: Function diagram

1 Measuring cell	2 A/D converter
3 Micro-controller	4 Keyboard
5 Switching outputs	6 LCD colour change display
7 D/A converter	

1.6 Design and mode of operation

The device is based on a ceramic sensor element that is suitable for measuring over-pressure and under-pressure. The pressure deforms the measuring membrane causing a change in resistance on the attached measuring bridge. This change is evaluated by the device's electronics and transformed into the display, switch contacts or an standardised analogue output signal.

The optional output signal can be dampened, spread, inverted and transformed via a table function even if it is non-linear. Overstepped limits can be visualised with the LCD colour change display.

The unit is configured with a keyboard or by means of remote configuration from a PC.

2 Technical Data

2.1 General Information

Reference conditions (acc. to IEC 61298-1)		
Temperature error	+15 ... +25 °C	
Relative humidity	45 ... 75 %	
Air pressure	86 ... 106 kPa	860 ... 1060 mbar
Installation position	User-defined	

2.2 Input variables

Relative pressure

Measuring range	Pressure safety		Characteristic curve deviation	
	Overpressure	Bursting pressure	Option	Default
0...+1.6 bar	4 bar (56 PSI)	7 bar	0.5%FS	1.0 % FS
0...+2.5 bar	10 bar	15 bar	0.5%FS	1.0 % FS
0...+4 bar	10 bar	15 bar	0.5%FS	1.0 % FS
0...+6 bar	20 bar	35 bar	0.5%FS	1.0 % FS
0...+10 bar	40 bar	70 bar	0.5%FS	1.0 % FS
0...+16 bar	40 bar	70 bar	0.5%FS	1.0 % FS
0...+25 bar	100 bar	150 bar	---	1.0 % FS
0...+40 bar	100 bar	150 bar	---	1.0 % FS
0...+60 bar	200 bar	250 bar	---	1.0 % FS

Vacuum and ± measuring ranges

Measuring range	Pressure safety		Characteristic curve deviation	
	Overpressure	Bursting pressure	Option	Default
0...-1 bar	4 bar (56 PSI)	7 bar	---	1.0 % FS
-1...0 bar	4 bar (56 PSI)	7 bar	---	1.0 % FS
-1...+0.6 bar	4 bar (56 PSI)	7 bar	---	1.0 % FS
-1...+1.5 bar	4 bar (56 PSI)	7 bar	---	1.0 % FS
-1...+3 bar	10 bar	15 bar	---	1.0 % FS
-1...+5 bar	20 bar	35 bar	---	1.0 % FS
-1...+9 bar	40 bar	70 bar	---	1.0 % FS
-1...+15 bar	40 bar	70 bar	---	1.0 % FS
-1...+24 bar	100 bar	150 bar	---	1.0 % FS

2.3 Output parameters

Analogue output

Output signal	Signal range	Apparent ohmic resistance
0...20 mA	0.0...21.0 mA	$R_L \leq 600 \Omega$
4...20 mA		
0...10 V	0.0...11.0 V	$R_L \geq 2 \text{ k}\Omega$

Switching outputs

2 potential-free relay contacts or
2 potential-free semiconductor switches (MOSFET)

	Relay	MOSFET
Progr. switching function	Open contact (NO) Break contact (NC)	One-pin activator (NO) One-pin deactivator (NC)
Max. switching voltage	32 V AC/DC	3...32 V AC/DC
Max. switching current	2 A	0.25 A
Max. switching output	60 W (VA)	8 W / 8 VA $R_{ON} \leq 1 \Omega$

2.4 Measurement accuracy

Non-linearity	Default	< 1.0 % FS
	Option ¹⁾	< 0.5 % FS
Hysteresis		< 0.5 % FS
Characteristic curve deviation ²⁾	Default	1.0 %
	Option ¹⁾	0.5 %
Temperature drift	Zero point	0.07 % FS/K
	Measuring range	0.05 % FS/K

¹⁾ only possible for certain measuring ranges

²⁾ incl. non-linearity and hysteresis

2.5 Auxiliary energy

Rated Voltage	24 V AC/DC
Admissible operating voltage	$U_b = 12...32$ V DC $U_b = 16.5...32$ V AC
Electrical connection	5-pin M12 circular plug connector

2.6 Application conditions**Ambient conditions**

Increase ambient temperature	-10 ... +70 °C
Media temperature	-10 ... +70 °C
Storage temperature	-20 ... +70 °C
Enclosure protection class	IP 65 acc. to EN 60529
EMC	EN 61326-1:2013 EN 61326-2-3:2013
RoHS	EN 50581:2012

Materials of the parts that come into contact with the surroundings

Housing	Stainless steel 1.4301	
Bayonet ring	Stainless steel 1.4301	
Front plate	Aluminium	
Front film	PET	Polyethylene terephthalate
Bayonet ring seal	NBR	Nitrile rubber
Blowout plug	FKM	Fluorocarbon rubber

Materials of the parts that come into contact with the measuring medium

Process connection	Stainless steel 1.4404	
Measuring diaphragm	ceramic	
Seal	FKM	Fluorocarbon rubber

2.7 Display and operating interface

Advertisement

4...6-digit LCD, full graphic, colour backlighting

Programming

Attenuation	0.0...100.0s (jump response 10/90%)
Switch output	Switch-off point, switch-on point, delay (0...1800s), function (NC / NO contact)
Measuring range unit	bar, PSI, kPa, "free unit", starting value, end value and decimal point for "free unit"
Output signal	User-definable within the basic measuring range ⁽¹⁾
Zero-point stabilising	0... $\frac{1}{3}$ of the basic measuring range ⁽²⁾
Zero point correction (off-set)	$\pm\frac{1}{3}$ of the basic measuring range ⁽³⁾
Implementation of characteristic curve	linear, square rooted, table with 3...30 support points
Password	001 ... 999 (000 = no password protection)

(1) Max. effective spread 4:1

(2) measured values around zero are set to zero.

(3) To compensate different installation positions.

2.8 Construction design

2.8.1 Dimensional picture

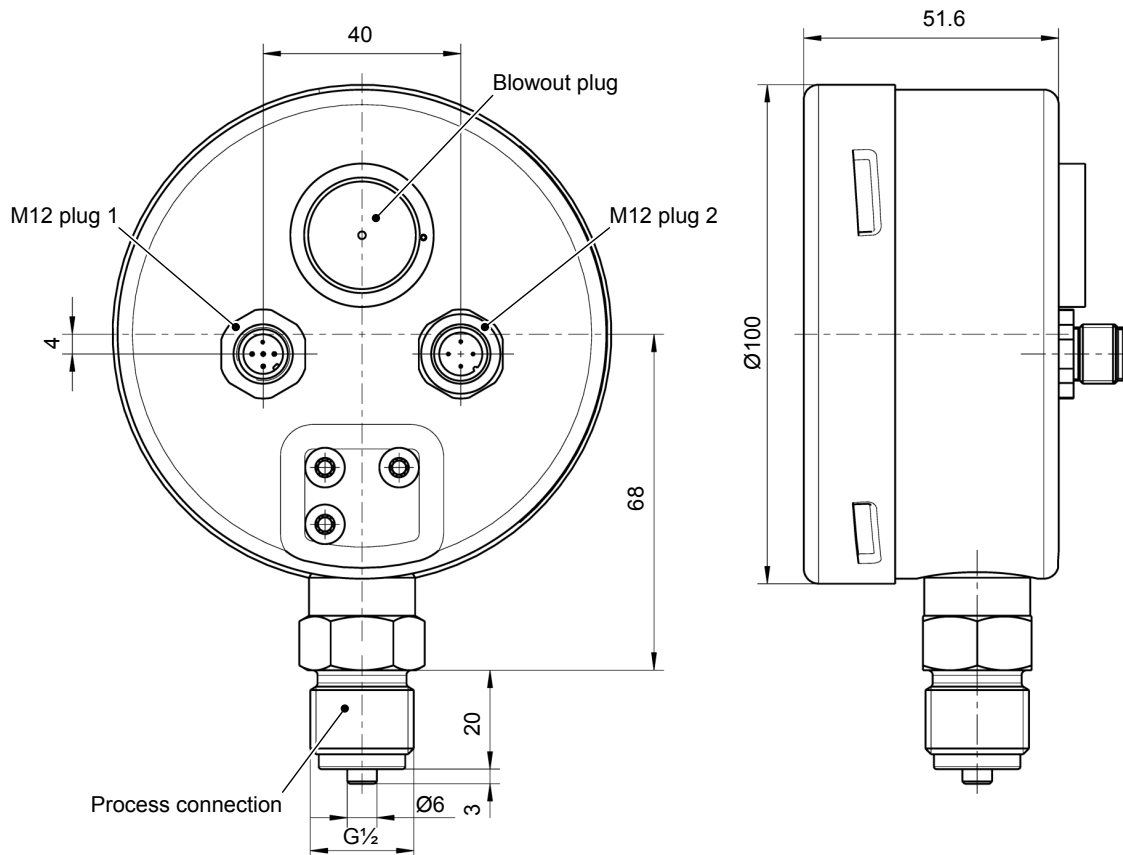

Illustration 5: Dimensional drawing

2.8.2 Process connection

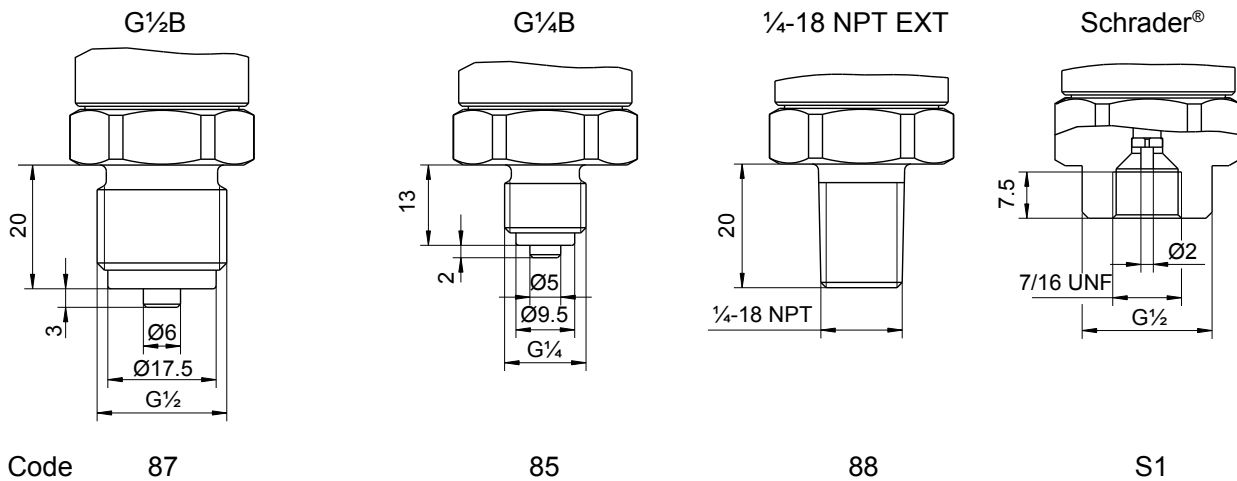

Illustration 6: Process connection

Port		Material
G $\frac{1}{2}$ B	Connection shanks with external thread	1.4404
G $\frac{1}{4}$ B	Connection shanks with external thread	1.4404
$\frac{1}{4}$ -18 NPT EXT	Connection shanks with external thread	1.4404
7/16 UNF	Connection with inner thread for the Schrader®- screw connection >	1.4404

2.8.3 Electrical connection

M12 flanged connector DIN EN 61076-2-101 coding A	
Connector 1	5-pin Ms-nickel-plated
Connector 2	4-pin Ms-nickel-plated

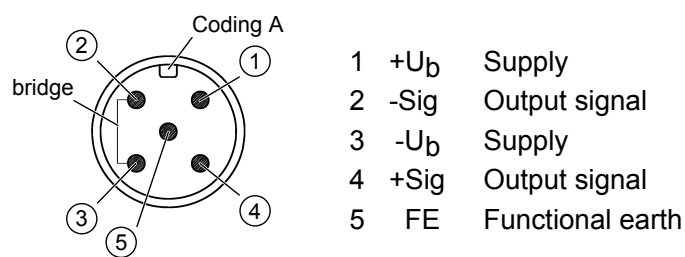

Illustration 7: Connector 1: Supply and output

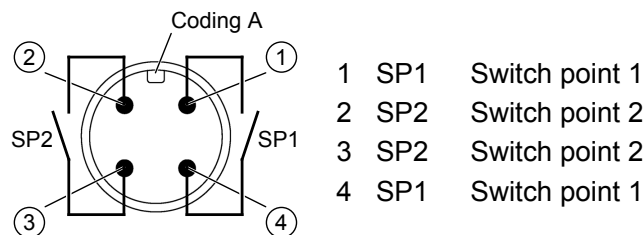
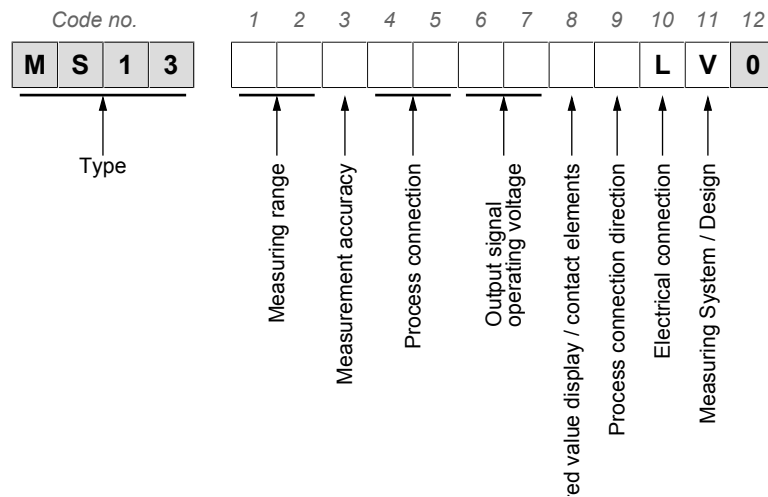

Illustration 8: Connector 2 Switch output

3 Order Codes



[1.2]	Measuring range	converted ranges	
	[bar]	[kPa]	[PSI]
03	0...1.6 bar	0 ... 160 kPa	0 ... 23.21 PSI
04	0...2.5 bar	0 ... 250 kPa	0 ... 36.26 PSI
05	0...4 bar	0 ... 400 kPa	0 ... 58.01 PSI
06	0...6 bar	0 ... 600 kPa	0 ... 87.02 PSI
07	0...10 bar	0 ... 1000 kPa	0 ... 145.0 PSI
08	0...16 bar	0 ... 1600 kPa	0 ... 232.1 PSI
09	0...25 bar	0 ... 2500 kPa	0 ... 362.6 PSI
10	0...40 bar	0 ... 4000 kPa	0 ... 580.1 PSI
11	0...60 bar	0 ... 6000 kPa	0 ... 870.2 PSI
31	-1...0 bar	-100 ... 0 kPa	-14.50 ... 0 PSI
32	-1...0.6 bar	-100 ... 60 kPa	-14.50 ... 8.702 PSI
33	-1...1.5 bar	-100 ... 150 kPa	-14.50 ... 21.75 PSI
34	-1...3 bar	-100 ... 300 kPa	-14.50 ... 43.51 PSI
35	-1...5 bar	-100 ... 500 kPa	-14.50 ... 72.52 PSI
36	-1...9 bar	-100 ... 900 kPa	-14.50 ... 130.5 PSI
37	-1...15 bar	-100 ... 15000 kPa	-14.50 ... 217.5 PSI
38	-1...24 bar	-100 ... 2400 kPa	-14.50 ... 348.1 PSI
39	0...-1 bar	0 ... -100 kPa	0 ... -14.50 PSI

[3]	Measurement accuracy
M	1.0 % characteristic curve deviation
0	0.5 % characteristic curve deviation

[4.5]	Process connection	Material
85	Connection shanks with external thread G $\frac{1}{4}$ B	
87	Connection shanks with external thread G $\frac{1}{2}$ B	1.4404
88	Connecting port with outer thread $\frac{1}{4}$ -18 NPT EXT	
S1	Schrader® screw connection inner thread 7/16 UNF	

[6.7] Output signal	Operating voltage		
EL 0 ... 20 mA	24 V AC/DC	3-wire version	
PL 4 ... 20 mA	24 V AC/DC	3-wire version	
CL 0 ... 10 V	24 V AC/DC	3-wire version	

[8] Measuring value display/switching elements		
C 4...6-digit colour change LCD	2 relay contacts	
D 4...6-digit colour change LCD	2 semiconductor switches	

[9] Process connection direction		
L Port left		
R Port right		
0 Port on top		
U Port below		

[10] Electrical connection		
L M12 connector socket Ms-nickel-plated		

[11] Measuring System / Design		
V FKM	Fluororubber, Viton®	

3.1 Accessories

Order no.	Designation	No. of Poles	Length
06401993	Connection cable for switching outputs with M12 connector	4-pin	2 m
06401994	Connection cable for switching outputs with M12 connector	4-pin	5m
06401995	Connection cable for supply/signal with M12 connector	5-pin	2 m
06401996	Connection cable for supply/signal with M12 connector	5-pin	5 m

Accessories acc. to data sheet MZ^{*)}

MZ310#	Wall mount acc. to DIN 16281
MZ1###	Siphons
MZ400#	Capillary throttle coil
MZ5###	Manometer shutoff valve acc. to DIN 16270/16271
MZ6###	Manometer shutoff valve acc. to DIN 16272

Parameter setting adapter^{*)}

EU05	Transmitter PC Interface incl. PC software
------	--

^{*)} A data sheet is available on our website or on request..

3.2 Information about the document

This document contains all technical data about the device. Great care was taken when compiling the texts and illustrations; Nevertheless, errors cannot be ruled out.

Subject to technical amendments.



FISCHER Mess- und Regeltechnik GmbH

Bielefelder Str. 37a
D-32107 Bad Salzuflen

Tel. +49 5222-974-0

Fax. +49 5222-7170

web : www.fischermesstechnik.de

eMail : info@fischermesstechnik.de

